



# REDUCING VALVE FOR STEAM

## MODEL DR20

### Features

**Extremely compact pressure reducing valve for use on small process equipment.**

1. Exceptionally light and compact PRV.
2. Wetted parts are of all stainless steel construction with high durability and corrosion resistance for long service life.
3. Stable secondary pressure.
4. High flow rate for its class.
5. Capable of a 30:1 pressure reduction.
6. Easy to operate and adjust.
7. Built-in screen ensures extended trouble-free operation.
8. Easy, in-line access to internal parts simplifies cleaning and reduces maintenance cost.



### Specifications

Model	DR20-2	DR20-6	DR20-10
Connection	Screwed, Flanged		
Size	1/2", 3/4", 1" / DN 15, 20, 25		
Maximum Operating Pressure (barg) PMO	16		
Maximum Operating Temperature (°C) TMO	220		
Primary Pressure Range (barg)	2 – 16		6 – 16
Adjustable Pressure Range (barg)	0.14 – 2, but not less than 1/30 of primary pressure	1.8 – 6	5.4 – 10
	Secondary pressure must not exceed 90% of primary pressure		

PRESSURE SHELL DESIGN CONDITIONS (NOT OPERATING CONDITIONS): Maximum Allowable Pressure (barg) PMA: 20      1 bar = 0.1 MPa  
 Maximum Allowable Temperature (°C) TMA: 220



To avoid abnormal operation, accidents or serious injury, DO NOT use this product outside of the specification range. Local regulations may restrict the use of this product to below the conditions quoted.

No.	Description	Material*	DIN	ASTM/AISI
①	Body	Cast Stainless Steel SCS13A	1.4308	A351 Gr. CF8
②	Cover	Cast Stainless Steel SCS13A	1.4308	A351 Gr. CF8
③	Screen	Stainless Steel SUS430	1.4016	AISI430
④	Coil Spring	Stainless Steel SUS304	1.4301	AISI304
⑤	Main Valve	Stainless Steel SUS420F	1.4028	AISI420F
⑥	Valve Seat Gasket	Fluorine Resin PTFE	PTFE	PTFE
⑦	Valve Seat	Stainless Steel SUS420F	1.4028	AISI420F
⑧	Spacer	Cast Stainless Steel SCS13A	1.4308	A351 Gr. CF8
⑨	Snap Ring	Stainless Steel SUS304	1.4301	AISI304
⑩	Valve Stem	Stainless Steel SUS303	1.4305	AISI303
⑪	Bellows	Stainless Steel SUS321	1.4541	AISI321
⑫	Cover Gasket	Fluorine Resin PTFE	PTFE	PTFE
⑬	Coil Spring	Stainless Steel SUS304	1.4301	AISI304
⑭	Spring Guide	Carbon Tool Steel SPCE	1.3243	A686 W1-8
⑮	Steel Ball	High-Cr Bearing Steel SUJ2	1.2067	A485
⑯	Cover Bolt	Stainless Steel SUS304	1.4301	AISI304
⑰	Locknut	Stainless Steel SUS304	1.4301	AISI304
⑱	Adjustment Handle	Stainless Steel SUS304	1.4301	AISI304
⑲	Nameplate	Stainless Steel SUS304	1.4301	AISI304
⑳	Retaining Ring	Stainless Steel SUS304	1.4301	AISI304
㉑	Flange	Cast Stainless Steel SCS13A	1.4308	A351 Gr. CF8

\* Equivalent material

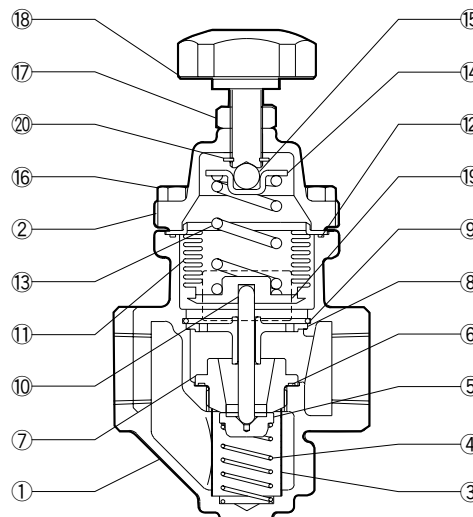

**Dimensions**

● **DR20**  
Screwed

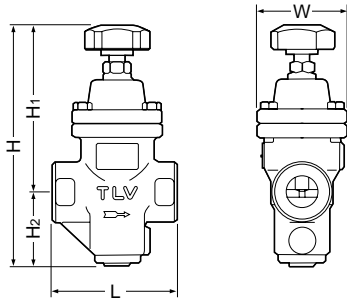

**DR20 Screwed\*** (mm)

Size	L	W	H	H <sub>1</sub>	H <sub>2</sub>	Weight (kg)
1/2"	95	69	185	130	57	1.9
3/4"						1.8
1"						

\* BSP DIN 2999, other standards available

● **DR20**  
Flanged

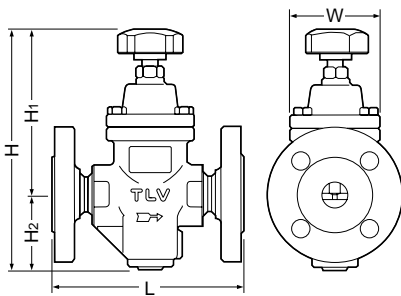

**DR20 Flanged\*** (mm)

DN	L	W	H	H <sub>1</sub>	H <sub>2</sub>	Weight (kg)
15	150	69	185	130	57	3.3
20						3.8
25	160					4.2

\* DIN 2501 PN 25/40, ASME Class 150RF, 300RF, other standards available

**Sizing Chart and Flow Graph**

The following graph is used for sizing the DR20 when adjusted for maximum flow.

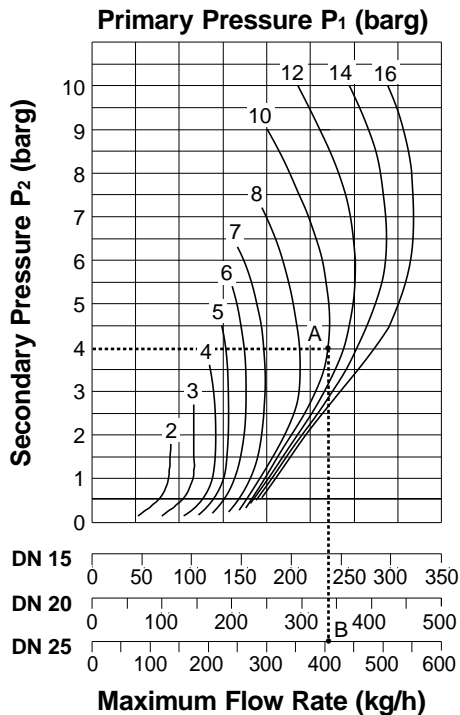

**Sizing Example**

For a primary pressure of 10 barg, a set pressure of 4 barg, and a maximum saturated steam flow rate of 400 kg/h, select an appropriate size.

Locate point A, where the primary pressure (P<sub>1</sub> = 10 barg) intersects the set pressure (P<sub>2</sub> = 4 barg).  
 Move straight down from point A until reaching a size with a rated flow rate exceeding the desired flow rate. This first occurs at point B on the DN 25 flow rate line.

- The DN 25 size should be selected.
- For a set pressure of 4 barg, model DR20-6 should be selected (see the adjustable pressure range information given in the specifications (overleaf)).

**Cv & Kvs Values**

Size (DN)	15	20	25
Kvs (DIN)	1.7	2.6	3.1
Cv (UK)	1.7	2.5	3.0
Cv (US)	2.0	3.0	3.6

Cv & Kvs values are for maximum flow

Manufacturer

ISO 9001/ISO 14001

